

Name: Rui Reis	Date: 2010-04-24/25
City: Portugal	Event: Camp Reg. Norte 2010
State: _____	Track: Avanca
Track Conditions: <input type="checkbox"/> Indoor <input type="checkbox"/> Tight <input type="checkbox"/> Smooth <input checked="" type="checkbox"/> Hard Packed <input checked="" type="checkbox"/> Blue Groove <input type="checkbox"/> Wet <input type="checkbox"/> Low Bite <input type="checkbox"/> High Bite <input checked="" type="checkbox"/> Outdoor <input checked="" type="checkbox"/> Open <input checked="" type="checkbox"/> Rough <input type="checkbox"/> Loose/Loamy <input type="checkbox"/> Dry <input type="checkbox"/> Dusty <input checked="" type="checkbox"/> Med Bite <input type="checkbox"/> Other _____	

Front Suspension

Toe: - 2,5°
 Ride Height: 27 mm.
 Camber: - 2,0°
 Caster: 12° Optional
 Sway Bar: 2,3 mm.
 Piston/Oil: 54 / 500 cps. RB
 Spring: Silver
 Limiter/Droop: 94 mm.
 Overall Shock Length: 94 mm.
 Steering Ackerman: Long
 Bump Steer: Up
 Camber Link: 3 / A
 Shock Location: 3 / Inside
 Receiver Battery Type: Orion 1600

Differentials

Front: Standard Smart
 Spring Wire Dia: _____
 Qty of Springs: _____
 Ramp Plate: _____
 Grease: _____
 Diff Fluid: 6.000 cps RB
 Center: Standard Smart
 Spring Wire Dia: _____
 Qty of Springs: _____
 Ramp Plate: _____
 Grease: _____
 Diff Fluid: 4.000 cps RB



Rear Suspension

Toe: + 3°
 Anti-Squat: 2°
 Ride Height: 3029 mm.
 Camber: - 2,0°
 Rear Hub Spacing: Middle
 Sway Bar: 2,3 mm.
 Piston/Oil: 56 / 300 cps. RB
 Spring: Silver
 Limiter/Droop: 105 mm.
 Overall Shock Length: 108 mm.
 Camber Link: 2 / B
 Shock Location: 2 / Inside
 Rear Diff Fluid: 2.000 cps Losi

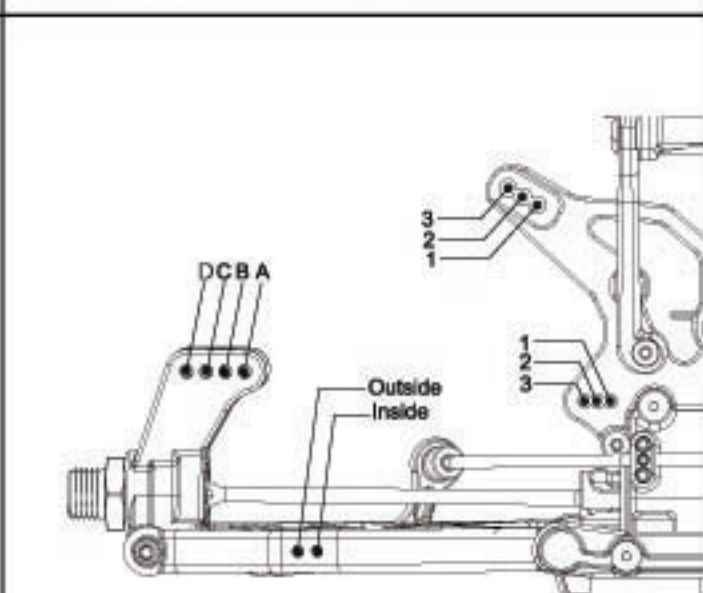

Engine

Engine: NR Plus 4 Fuel: Meccatop 25%
 Glow Plug: NR # C6 TGC Head Clearance: .30
 Pipe/Header: NR 9901 Gearing: 13 / 46

Clutch

Clutch Shoes and Springs Info

- 2 x Aluminium Shoes
- 2 x Carbon Shoes
- 2 x Black Springs
- 2 x Green Springs

Tires

	Type	Compound	Insert
Front:	<u>AKA Gridiron</u>	<u>Soft</u>	<u>AKA original</u>
Rear:	<u>AKA Gridiron</u>	<u>Soft</u>	<u>AKA original</u>

Notes: **O pneu agarrou cada vez mais, no decorrer da final. VITÓRIA.**